

# PRODUCT INFORMATION

PRELIMINARY/β

1300nm  
1550nm  
**8C443**  
PIN/Preamp

**Datacom, Telecom**

This device consists of a PIN photodiode and a transimpedance amplifier assembled in a TO-46 package. It is designed for FDDI, ATM and SDH/Sonet up to 155 Mbps. The AGC (Automatic Gain Control) ensures a wide dynamic range. Its double-lens optical system is designed for single-mode fiber as well as for multimode fiber with core diameter up to 62.5μm.

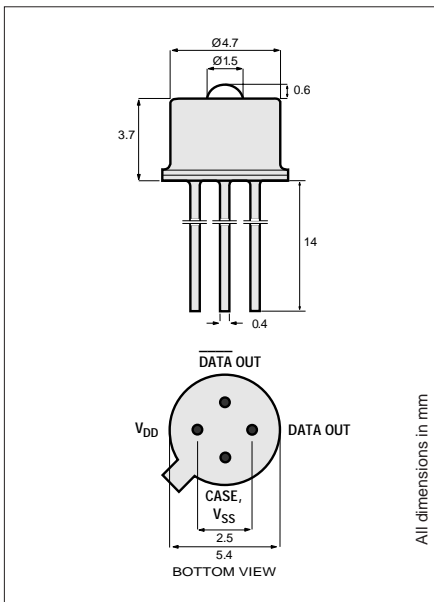

**TO-46 Package With Lens**

## Optical and Electrical Characteristics (25° C Case Temperature)

PARAMETER	SYMBOL	MIN.	TYP.	MAX.	UNIT	TEST CONDITION
Responsivity, single ended differential	$R$		100 200		kV/W	$\lambda=1300$ nm Note 1
Output Voltage (differential, peak to peak)	$V_O$			1.2	V	
Bandwidth (3 dB <sub>el</sub> )	$f_c$		140		MHz	$P_f=1$ μW
Noise-Equivalent Power	$NEP$		15		nW	$\lambda=1300$ nm
Sensitivity (BER 10 <sup>-9</sup> )	$S$		-39		dBm	$\lambda=1300$ nm Extinction Ratio=0
Dynamic Range		36	40		dB	
Output Resistance (differential)	$R_O$		50		Ω	
Power Supply Current	$I_{DD}$		32	40	mA	

**Operating Conditions:** See table below. Fiber: Single-mode to multimode 62.5/125μm.  
**Note 1:**  $P_f=1$  μW average power at 10MHz/50% duty cycle.

## Absolute Maximum Ratings

PARAMETER	SYMBOL	MIN.	MAX.	UNIT
Supply Voltage	$V_{DD}-V_{SS}$	0	6.0	V
Operating Temperature	$T_{Op}$	-40	85	°C
Storage Temperature	$T_{Stg}$	-55	125	°C

## Recommended Operating Conditions

PARAMETER	SYMBOL	MIN.	TYP.	MAX.	UNIT
Supply Voltage	$V_{DD}-V_{SS}$	4.5	5.0	5.25	V
Output Differential Load	$R_L$	1	3		kΩ

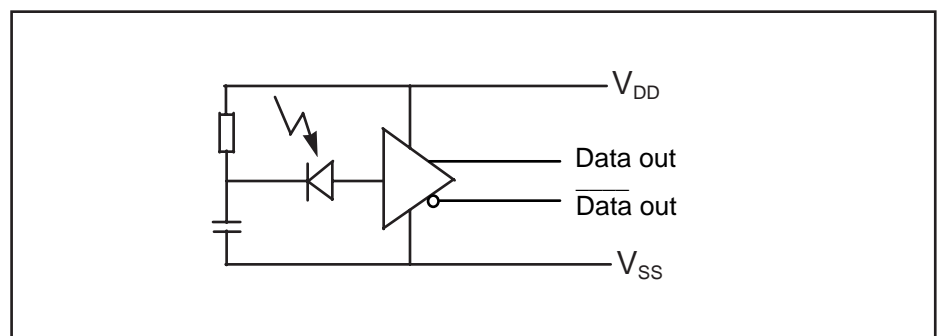

**Functional schematic**

13451.11 1998-02-04



Europe: Tel (46) 8 58 02 45 00 Fax (46) 8 58 02 01 10  
 Tel (44) 1291 436180 Fax (44) 1291 436771

America: Tel 1-800-96MITEL Fax (613) 592-6909  
 Asia: Tel (65) 293 5312 Fax (65) 293 8527